

12 MP (4K Ultra HD) IR Bullet IP Cameras

HBD8GR1

Honeywell is taking quality and reliability to the next level with the new equiP® line of 4K Ultra HD IP bullet cameras. The Honeywell TDN Ultra HD IR rugged bullet cameras offer incomparable picture clarity, hassle-free flexible system integration, and secure data transmission—and they install easily too!

Ultra HD 4K Image Quality

- Ultra HD 12 MP (4K) 20 fps image with a 1/1.7" 12 megapixel progressive scan CMOS, or full HD 8 MP 25/30 fps image
- Digital WDR (DWDR) ensures glare-free images
- True Day/Night provides vivid colour images by day and clear black-and-white images at night using a removable IR cut filter
- Excellent low-light performance with 3D noise reduction, saving storage and bandwidth together with H.265 Profile codec

Flexible Surveillance Solution

- 5.1–12.8 mm, F1.7, motorized focus/zoom lens
- H.265, H.264 and MJPEG codec, triple stream support
- IR LEDs provide up to 65m (210 ft) of illumination in dimly lit or nighttime scenes (depending on scene reflectance)
- Smart IR technology provides even distribution of IR
- Waterproof (IP67) and IK10 impact-resistant camera housing
- –40°C to 60°C (–40°F to 140°F) working temperature
- ONVIF Profile S and G compliant
- Security features include individual signed certificates and data encryption
- Cameras can be retrofitted on many existing DVR/NVR installations without requiring additional storage.

Easy to Install and Use

- Built-in PoE+ (Power over Ethernet 802.3at) eliminates separate power supply and associated wiring; 24 V AC/12 V DC inputs where PoE power is unavailable.
- Remote configuration, motorized zoom adjustments and auto focus through web client or from the NVR
- Included accessories: security screw driver, mounting screws, conduit adapter, and mounting template



(Back box sold separately)



Onboard Video Storage

Supports up to 128 GB microSDHC (Class 10) card for local video storage when network is interrupted. Card not included.

Market Opportunities

These fully featured attractive cameras are perfect for outdoor installations that require excellent picture quality at minimal bandwidth while offering maximum protection against dust, dirt, and water. Boasting a sleek modern design and offering 4K high definition images, the cameras are suited for a wide range of applications.

FEATURES AND BENEFITS

- | | | | | |
|---|--|---|---|---|
| <ul style="list-style-type: none"> • Ultra HD 4K/12 MP resolution at 20 fps or 8 MP at 25/30 fps • Up to triple stream support • 65 m (210 ft) IR distance, depending on scene reflectance | <ul style="list-style-type: none"> • 1/1.7" 12 megapixel progressive scan CMOS imager • Excellent low light performance with down to 0 lux BW (with IR LEDs on) • Digital WDR | <ul style="list-style-type: none"> • Choice of 24 V AC, 12 V DC or PoE+ (802.3at) power inputs • 5.1–12.8 mm, F1.7, motorized focus and zoom lens • Rugged outdoor housing with IP67 ingress protection rating and IK10 impact resistance rating | <ul style="list-style-type: none"> • Corridor mode viewing capability • On board camera storage up to 128 GB microSD card (not included) • ONVIF profile S and G compliant | <ul style="list-style-type: none"> • Built-in cybersecurity hardware chipset • Global language support with 15 languages for all QIGs, Web GUI, and online help |
|---|--|---|---|---|

HBD8GR1 Features

The camera can be configured to automatically detect and respond to events such as motion in the scene, alarm inputs, network failure, and/or camera tampering. Automated responses include: sending a notification through email, FTP, and/or HTTP; sending a still image of the event through email and/or FTP; and recording a video clip of the event to a configured microSDHC card. Setup can be done through the web client.

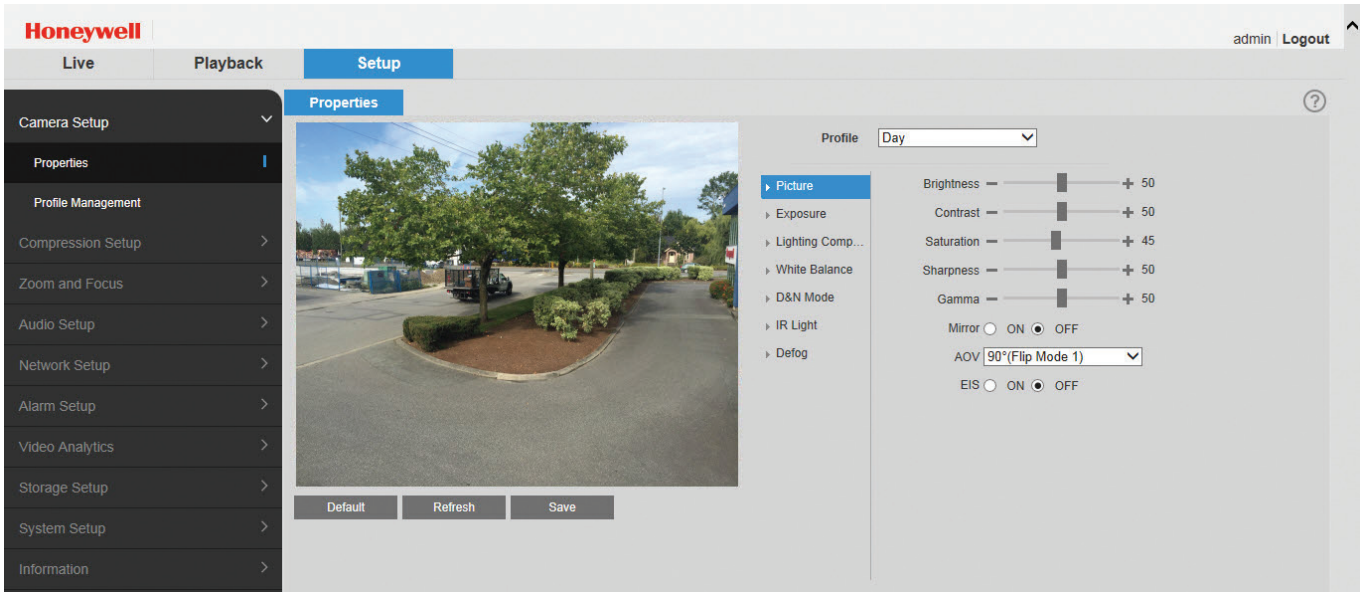

Dimensions

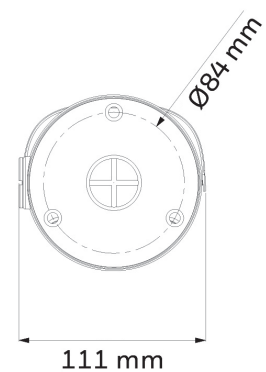
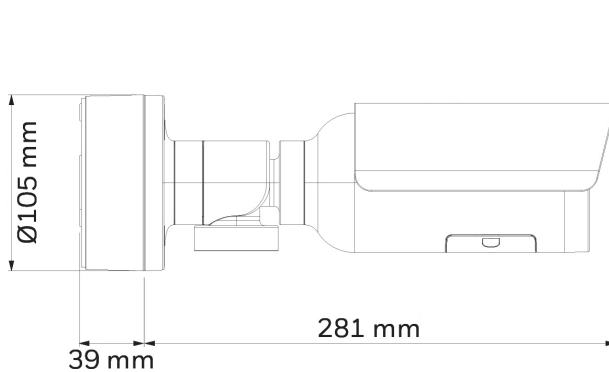
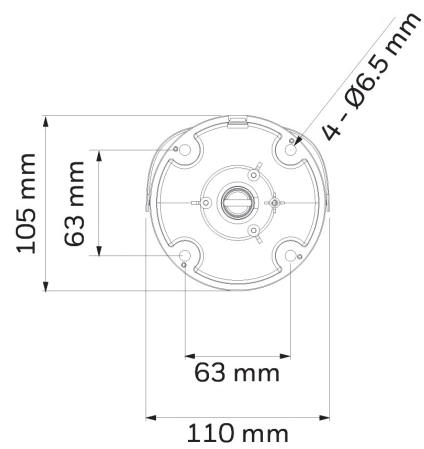
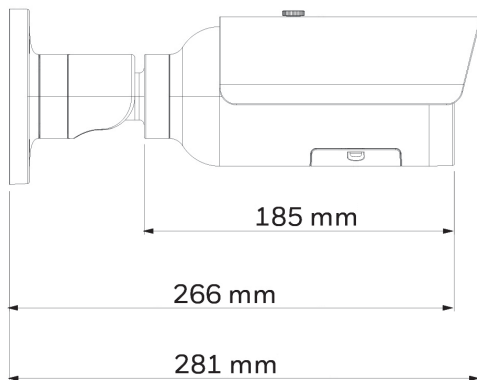





HBD8GR1 Technical Specifications

OPERATIONAL		
VIDEO STANDARD	NTSC/PAL	
SCANNING SYSTEM	Progressive scan	
IMAGE SENSOR	1/1.7" 12 MP progressive CMOS	
NUMBER OF PIXELS (H×V)	4000 × 3000	
MINIMUM ILLUMINATION	0.02 lux colour @ F1.7/0 lux B/W with IR LEDs on @ F1.7	
S/N RATIO	50 dB	
ELECTRONIC SHUTTER SPEED	Auto, Manual, 1/3(4)–1/100 000 s	
IR DISTANCE	Up to 65 m (210 ft), depending on scene reflectance	
DAY/NIGHT	Auto(ICR)/Colour/BW	
BACKLIGHT COMPENSATION	BLC/HLC/DWDR/SSA	
WIDE DYNAMIC RANGE	Digital WDR (DWDR)	
WHITE BALANCE	Auto/Natural/Street Lamp/ Outdoor/Customize Region	
GAIN CONTROL	Auto/Manual	
NOISE REDUCTION	3DNR	
PRIVACY MASKING	Up to 4 areas	
CORRIDOR MODE	Yes	
ELECTRONIC IMAGE STABILIZATION	Off/On	
DEFOG	Auto/Manual/Off	
LENS	5.1–12.8 mm, MFZ, F1.7	
HORIZONTAL ANGLE OF VIEW	86°–35°	
AUDIO/TWO-WAY	Line In/Out	
ALARM INPUT/OUTPUT	2/1	
ETHERNET	RJ-45 (10/100/1000Base-T)	
ANALOG OUTPUT	BNC Connector	
IP SPECIFICATIONS		
VIDEO COMPRESSION	H.265/H.264+/H.264/MJPEG Bit rate control (CBR and VBR)	
RESOLUTION	16:9	8M (3840×2160) / 3M (2304×1296) / 1080p (1920×1080) / 720p (1280×720)
	4:3	12M (4000×3000) / 5M (2560×1920) / 3M (2048×1536) / 1.3M (1280×960) / VGA (640×480) / CIF (352×288/352×240)
	OTHER	8M (4096×2160) / 6M (3072×2048) / SXGA (1280×1024) / D1 (704×576/704×480)
FRAME RATE	MAIN STREAM	12M (4000×3000) 1–20 fps / 8M (4096×2160) or lower resolution at 1–25/30 fps
	SUB STREAM	D1/VGA/CIF up to 25/30 fps
	TRIPLE STREAM	1080p/720p/D1/VGA up to 25/30 fps
AUDIO COMPRESSION	G.711a/G.711Mu/AAC/G.726	
AUDIO STREAM	Full duplex, simplex	
SD CARD FUNCTION	Event trigger recording Continuous and scheduled recording Automatic recording when network fails	
SD CARD	Up to 128 GB microSDHC card Class 10 (not included)	

IP SPECIFICATIONS (CONT'D)	
PROTOCOLS*	IPv4/v6, TCP/IP, UDP, RTP, RTSP, HTTP, HTTPS, SSL, ICMP, FTP, SMTP, DHCP, PPPoE, UPnP, IGMP, SNMP, Bonjour, DNS, DDNS, IEEE 802.1X, QoS, NTP, IP Filter, Multicast, ONVIF
COMPATIBILITY	ONVIF Profile S/G
MAX. USER ACCESS	20 users
SUPPORTED WEB BROWSERS	Internet Explorer (11.0+), Firefox, Chrome
SUPPORTED OS	Windows 7 32-bit/64-bit, Windows 10
SECURITY	User account and password protection, HTTPS, IP Filter, IEEE 802.1X, digest authentication, user access log, TLS1.2, AES-256, SSH/Telnet closed, FTP disabled, PCI-DSS, built-in crypto chipset, UL2900-1, UL Cyber Assurance Program (UL CAP) certification
LANGUAGES SUPPORTED	English, Arabic, Czech, Dutch, French, German, Italian, Japanese, Korean, Polish, Portuguese, Russian, Simplified Chinese, Spanish, Turkish
ELECTRICAL	
POWER SUPPLY	PoE+ (802.3at) Class 4, 12 V DC/24 V AC
AC FREQUENCY	50/60 Hz
POWER CONSUMPTION	18 W max. (IR LEDs on, motorized lens working)
MECHANICAL	
DIMENSIONS	281.0 × 110.0 mm (11.1 × 4.3 in.)
PRODUCT WEIGHT	4.4 lb (2.0 kg)
PACKAGE WEIGHT	5.0 lb (2.3 kg)
CONSTRUCTION	Die-cast aluminum housing with powder coat
CONSTRUCTION Colour	RAL9003 (White) and RAL7022 (Gray)
ENVIRONMENTAL	
TEMPERATURE	–40°C to 60°C (–40°F to 140°F)
RELATIVE HUMIDITY	Less than 95%, non-condensing
INGRESS PROTECTION	IP67
IMPACT RESISTANCE	IK10
REGULATORY	
EMISSIONS	EN 55032, FCC Part 15B AS/NZS CISPR 22:2009+ A1 (2010)
IMMUNITY	EN50130-4
SAFETY	EN 60950-1, EN 60950-22 UL Listed to UL/CSA 60950-1, 60950-22
ROHS	EN 50581

*Some development may be required in specific user cases to support some of these protocols in the field as they mature over time.

ORDERING

SYSTEM INTEGRATION		ACCESSORIES	
OPEN IP INTEGRATION		HOUSINGS AND MOUNTS	
<p>ONVIF support and open API software integration. Refer to www.onvif.org for the ONVIF specification and the Honeywell Open Technology Alliance website (http://www.security.honeywell.com/hota/) to learn more about our open and integrated solutions.</p>		<p>HBG-BB  IP66 Back Box with Gasket (for Cable Termination)</p>	
		<p>HBG-FP  Front Lens Plate Replacement (if Vandalized)</p>	
		<p>HB4G-PM  Pole Mount Adapter</p>	
		<p>HB34G-CM  Corner Mount Adapter</p>	

HONEYWELL DEVICE INTEGRATION	
MAXPRO® NVR FAMILY	Entry to Enterprise Level Network Video Recorders (version 4.0 and greater)
MAXPRO® VMS FAMILY	Entry to Enterprise Level Network Video VMS (version R410 and greater)
DVM	DVM R600.1 SP1
HUS	HUS 5.1

ORDERING	
CAMERAS	
HBD8GR1	Network TDN Ultra 4K HD IR Bullet Camera, 1/1.7" CMOS, 12 MP, 5.1-12.8 mm MFZ, 4 IR LEDs, PoE+, H.265

NOTE:
Honeywell reserves the right, without notification, to make changes in product design or specifications.

For more information

security.honeywell.com/uk

Honeywell Commercial Security

Aston Fields Road
Whitehouse Industrial Estate
Runcorn
Cheshire
WA7 3DL
UK
Tel: 08448 000 235
Fax: +44 (0)1928 754 050
www.honeywell.com

HSV-HBD8GR1-02-UK(1118)DS-E
© 2018 Honeywell International Inc.

